



TECH SPECS

High Flow Commercial Control Zone Kits with Pressure-Regulating, Quick-Check Basket Filters

XCZ-100-PRB-COM



1" Kit – Now 24% Shorter

XCZ-150-PRB-COM



1 1/2" Kit – Now 22% Shorter

Rain Bird simplifies drip with the highest flow control zone kits on the market. Both kits contain time-tested Rain Bird valves and now also feature the new and innovative Pressure Regulating, Quick-Check Basket Filter.

The simplest and most reliable Control Zone Kits for a wide range of commercial drip irrigation applications.

Benefits

- **Reduces Installation Labor Costs** – Fewer joints to complete which reduces assembly time.
- **Reduces Ongoing Maintenance Cost** – The high capacity filter with indicator bubble ensures the filter will be cleaned only when needed.
- **Improves reliability** – The kits are made up of high quality components including the PESB (scrubber) valve and the 40 psi (2,8 bars) Pressure-Regulating, Quick-Check Basket Filter. The indicator bubble shows when the filter needs to be cleaned.
- **Saves Time for Specifiers** – One part number to specify, one part number to order. Overall pressure loss, and pressure rating of the entire assembly is provided.

Features

Scrubber Valve

- **Debris Tolerant** – Plastic scrubber scrapes the stainless steel screen to clean and break down grit and organic materials.
- **Easy Servicing** – One-piece solenoid with captured plunger and spring prevents loss

of parts during field service.

- **Protects Down Stream Components** – Slow closing prevents water hammer and subsequent system damage.
- **Rugged Construction** – The body is made from impact resistant glass-filled polypropylene and the cap is constructed of glass-filled nylon.
- **Long Life** – The diaphragm is reinforced with fabric which adds strength and durability.

Pressure-Regulating, Quick-Check Basket Filter

- **Efficient Design** – Combines filtration and pressure regulation in one compact unit.
- **Increases Reliability** – Fewer connection points means less chance of leaking.
- **Reduces Costs** – Combined parts mean less assembly time, and compact size means smaller valve boxes.
- **Reduces Maintenance** – Save labor time with the simple-to-check indicator bubble and easy-to-clean stainless steel filter.
- **Protects Drip Irrigation Components** – Comes standard with a 200 mesh (75 micron) stainless-steel filter element.
- **Rugged Construction** – The body is made of durable, glass-filled nylon. Stainless steel studs, molded into the body, resist thread damage.
- **Easy to Access** – The filter design allows the

element to be accessed vertically while preventing debris from falling into the line.

Additional Elements

- **1" Control Zone comes with PVC Tee** – This kit includes a pre-glued "Tee" and is partially assembled with all threads pre-taped.
- **1 1/2" Control Zone comes with PVC Tee** – This kit includes a pre-glued "Tee" and is partially assembled with all threads pre-taped.

Quick-Check Filter





1" Commercial Control Zone Kit with PR Basket Filler



Model: XCZ-100-PRB-COM

Specifications

Control zone kit shall be Rain Bird's 1" Commercial Control Zone Kit with PR Basket Filter. It shall contain a 1" ball-type shut-off valve, a 1" automatic irrigation control valve with self-scrubbing feature, and Pressure-Regulating, Quick-Check Basket Filter. The system shall be pressure rated to 150 psi (10,3 bar) and be capable of flow rates of 3.0 to 20.0 gpm (11,4 to 75,7 l/m).

The PR Basket Filter shall contain a 200 mesh, stainless-steel filter and a built-in 40 psi (2,8 bar) pressure regulator. The body of the unit shall be constructed of impact resistant glass-filled polypropylene and the cap of glass-filled nylon with a UV resistant polyurethane indicator window. The unit shall incorporate an indicator window that shows when the filter needs to be cleaned.

The automatic irrigation control valve shall be normally closed, solenoid activated at 24 VAC 50/60 Hz, and balance pressure type. The valve body and bonnet shall be constructed of high impact, weather resistant plastic, stainless steel, and other chemical / UV resistant materials. The valve shall have a diaphragm constructed of durable Buna-N rubber with a clog-resistant metering orifice. The valve shall have one 90 mesh (200 micron) filter attached to the solenoid base. The kit shall be manufactured by Rain Bird Corporation of Azusa, California.

Model: XCZ-100-PRB-COM High Flow Kit with 1" PESB Valve, a Pressure Regulating, Quick-Check Basket Filter (a 40 psi Pressure Regulator built-in) with 200 mesh (75 micron) screen, a shut-off ball valve and a schedule 80 PVC nipple.

Operating Range

- Flow: 3.0 to 20.0 gpm (11,4 to 75,7 l/m)
- Pressure: 15 to 150 psi (1,0 to 10,3 bar)
- Regulating Pressure: 40 psi (2,7 bar)
- Temperature: up to 150° F (66° C)
- Filtration: 200 mesh (75 micron)*

*Can be replaced with 100 mesh Rain Bird filter, available separately

XCZ-100-PRB-COM	
Flow (gpm)	Minimum Inlet for Regulated Outlet Pressure (psi)†
3.0	42.0
5.0	44.0
10.0	47.3
15.0	53.0
20.0	62.5

XCZ-100-PRB-COM Metric	
Flow (L/m)	Minimum Inlet for Regulated Outlet Pressure (bar)†
11,4	2,9
18,9	3,0
37,9	3,3
56,8	3,6
75,7	4,3

† Note: Regulated outlet pressure is ±10% of nominal

Electrical Specifications

- 24 VAC 50/60 Hz (cycles/sec) solenoid
- Inrush current: 0.41 A (9.48 VA) at 60 Hz
- Holding current: 0.28 A (6.72 VA) at 60 Hz
- Coil resistance: 30-39 ohms

How to Specify/Order

XCZ-100-PRB-COM

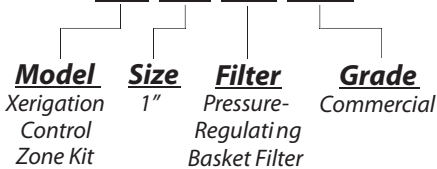

The High Flow 1" Commercial Zone Kit Dimensions

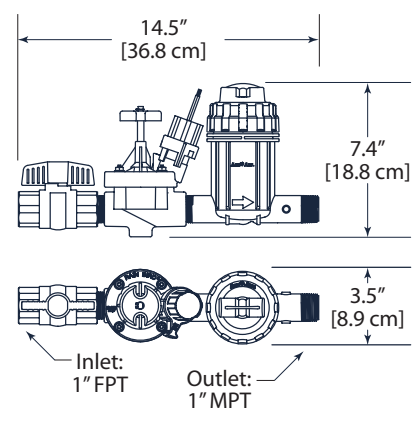

Dimensions

Length: 14.5 in [36.8 cm]
 Width: 3.5 in [8.9 cm]
 Height: 7.4 in [18.8 cm]



1 1/2" Commercial Control Zone Kit with PR Basket Filler



Model: X CZ-150-PRB-COM

Specifications

High Flow Commercial Control Zone Kit for zones with flows from 15.0 to 40.0 GPM (56,8 to 151,4 l/m).

Control zone kit shall be Rain Bird's 1 1/2" Commercial Control Zone Kit with Rain Bird's 1 1/2" PESB valve, two Pressure-Regulating, Quick-Check Basket Filters with built-in 40 psi pressure regulators and 200 mesh (75 micron) stainless steel screens.

The filter shall be two 1" Pressure-Regulating, Quick-Check Basket Filter bodies constructed of heavy-duty, glass-filled, UV resistant polypropylene capable of withstanding pressures of not less than 150 psi (10, bars). The design shall be a basket style body with jar-top cap. The cap shall incorporate an indicator that goes from green to red during operation when the filter element needs cleaning. The filter elements shall be constructed of a durable stainless steel mesh attached to a glass-filled polypropylene frame and shall be a standard 200-mesh (75 micron). The screen shall be serviceable for cleaning purposes by unscrewing the cap from the body and removing the filter element.

The control zone kit shall have two in-line pressure regulators built into the Basket Filter. The pressure regulators shall be constructed of durable, UV resistant non-corrosive material able to accommodate an inlet pressure rating of not less than 150 psi (10,3 bars). The pressure regulating device is a normally open device that allows full flow with little pressure loss unless the inlet pressure is greater than the preset level. As the inlet pressure increases above the preset level it compresses a spring and begins to reduce the downstream pressure. The inline pressure regulator shall have a preset outlet pressure of approximately 40 psi (2,8 bars).

The control zone kit shall have a 1 1/2" PESB series automatic irrigation control valve. The pressure rating not to be less than 150 psi (10,3 bars). The valve body and bonnet shall be constructed of high-impact, weather-resistant plastic, stainless steel and other chemical/UV resistant materials. The valve

X CZ-150-PRB-COM	
Flow (gpm)	Minimum Inlet for Regulated Outlet Pressure (psi) [†]
15.0	40.0
20.0	49.0
25.0	50.2
30.0	53.5
35.0	56.1
40.0	60.7

X CZ-150-PRB-COM Metric	
Flow (L/m)	Minimum Inlet for Regulated Outlet Pressure (bar) [†]
56,8	2,8
75,7	3,4
94,7	3,5
113,6	3,7
132,5	3,9
151,4	4,2

[†] Note: Regulated outlet pressure is ±10% of nominal

shall have a diaphragm constructed of a durable Buna-N rubber material reinforced with nylon. The kit shall be manufactured by Rain Bird Corporation of Azusa, California.

Model: X CZ-150-PRB-COM High Flow Kit with 1 1/2" PESB Valve, two Pressure Regulating, Quick-Check Basket Filters (with 40 psi Pressure Regulator built into each one) with 200 mesh (75 micron) screens and a schedule 40 PVC tee.

Operating Range

- Flow: 15.0 to 40.0 gpm (56,8 to 151,4 l/m)
- Inlet Pressure: 20 to 150 psi (1,4 to 10,3 bar)
- Regulating Pressure: 40 psi (2,8 bars)
- Temperature: up to 150° F (66° C)
- Filtration: 200 mesh (75 micron)*

*Can be replaced with 100 mesh Rain Bird filter, available separately

Electrical Specifications

- 24 VAC 50/60 Hz (cycles/sec) solenoid
- Inrush current: 0.41 A (9.48 VA) at 60 Hz
- Holding current: 0.28 A (6.72 VA) at 60 Hz
- Coil resistance: 30-39 ohms

How to Specify/Order

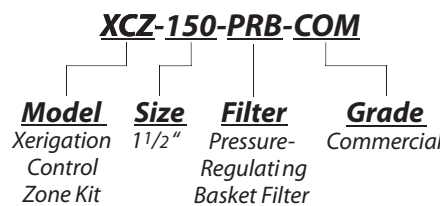

The High Flow 1 1/2" Commercial Zone Kit Dimensions

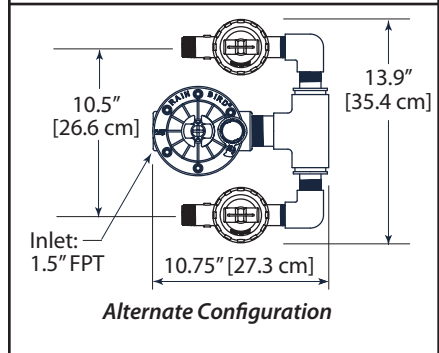
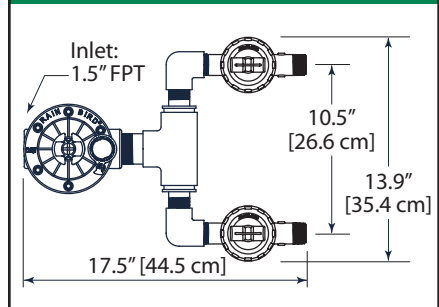

Dimensions

- Length: 17.5 in (44.5 cm)
- Width: 13.9 in (35.4 cm)
- Height: 7.4 in (18.8 cm) (Top configuration)
- Length: 10.75 in (27.3 cm)
- Width: 13.9 in (35.4 cm)
- Height: 7.4 in (18.8 cm) (Alternate configuration)



Replacement Stainless Steel Screen Elements

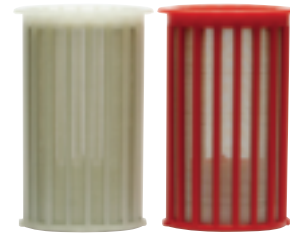

QCKCHK-200M QCKCHK-100M

Stainless Steel Screen Elements

The _____ mesh stainless steel screen element shall be used inside the Pressure-Regulating, Quick-Check Basket Filter and shall be constructed of stainless steel welded to a color-coded, glass-filled polypropylene frame. The screen element shall be used in the 1" model and match the filtration requirements of the emission device or sprinkler. Screen mesh sizes shall be designated by the following color code: red – 100 and natural – 200 mesh. The stainless steel screen element shall be supplied by Rain Bird Sprinkler Mfg Corporation, Azusa, California.

Filter Elements

- QKCHK-100M
(100 mesh / 150 micron, red housing)
- QKCHK-200M
(200 mesh / 75 micron, white housing)

How to Specify/Order

Basket Filter Elements

QKCHK-100M

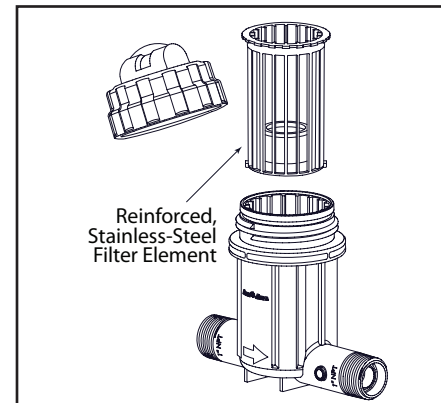
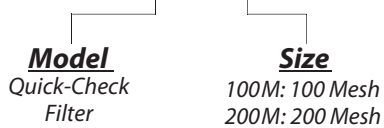

Stainless Steel Screen Element Dimensions (Inches)

Filter Size	Diameter	Height	Area of Filtration (in ²)
1"	2.5"	4"	16.26"

Stainless Steel Screen Element Dimensions (Metric)

Filter Size	Diameter	Height	Area of Filtration (in ²)
2,54 cm	3,35 cm	10,16 cm	41,30 cm

Rain Bird Corporation

Contractor Division
970 West Sierra Madre Avenue, Azusa, CA 91702
Phone: (626) 963-9311 Fax: (626) 812-3411

Rain Bird Corporation

Commercial Division
6991 E. Southpoint Road, Tuscon, AZ 85756
Phone: (520) 741-6100 Fax: (520) 741-6146

Rain Bird International, Inc.

970 West Sierra Madre Avenue, Azusa, CA 91702
Phone: (626) 963-9311 Fax: (626)963-4287

Rain Bird Technical Services

(800) 247-3782 (U.S. only)

Specification Hotline

800-458-3005 (U.S. and Canada)

www.rainbird.com

The Intelligent Use of Water™ – Visit www.rainbird.com
to learn about our efforts

®Registered Trademark of Rain Bird Corporation
©2008 Rain Bird Corporation 11/08

D39843